

# Hydraulic Clutch Control

*Installation & Maintenance Manual*

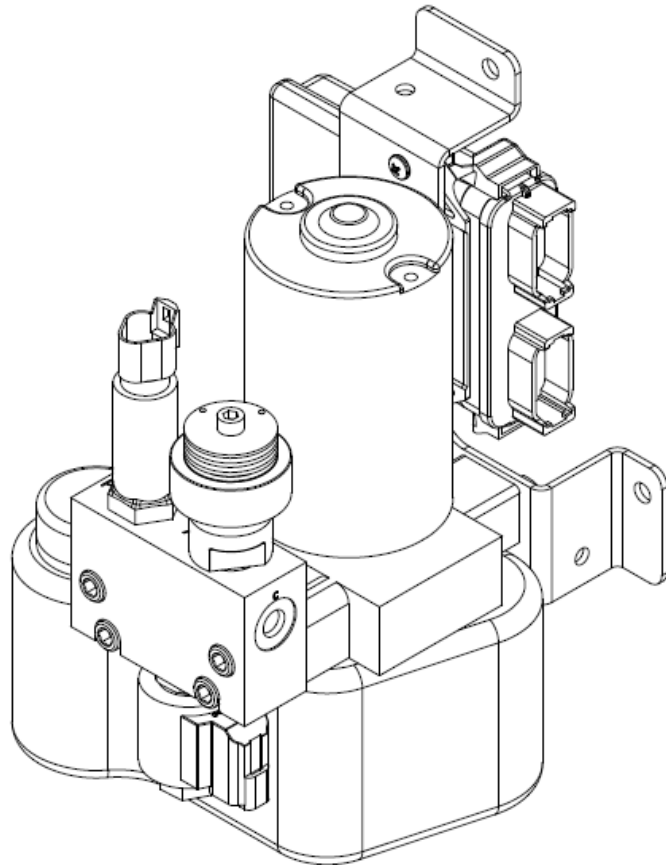

# Contents

---

- 1.0 CAUTIONS & WARNINGS .....3
- 2.0 SPECIFICATIONS..... 4
- 3.0 MAINTENANCE .....4
- 4.0 INSPECTION .....4
- 5.0 INSTALLATION..... 5
- 6.0 OPERATION..... 6
- 7.0 DISASSEMBLY ..... 6
- 8.0 ADJUSTMENT OF ENGAGEMENT SEQUENCE .....7
- 9.0 ASSEMBLY..... 9
- 10.0 GRAPHIC OVERLAY..... 10
- TROUBLESHOOTING GUIDE ..... 14
- ASSEMBLY DRAWINGS & PARTS LIST..... 15
- MOUNTING LOCATION DRAWING ..... 16
- WIRING DIAGRAM – CUSTOMER CONNECTION..... 17

# Cautions and Warnings

## 1.0 INTRODUCTION

- 1.1 The WPT Power Hydraulic Clutch Control (HCC) was designed with the user in mind, to operate independently from the machine's hydraulic system and for seamless integration with the machine. The HCC is primarily intended for machines whose engines are easily stalled when engaging the PTO. The HCC, when put into service with a WPT Hydraulic PTO, will accelerate the primary machine functions with relative ease.
- 1.2 Use the part number from the Bill of Materials (BOM) supplied with this unit when ordering parts. Include the part number and the serial number from the unit itself. These are located on the outside of the enclosure, as shown in figures and drawings. Your WPT Distributor can provide a copy of the BOM, if the one provided should be lost.

### **DANGER**

Read these instructions thoroughly and review until you fully understand all warnings and hazards before proceeding with the work described in this manual. Failure to follow these instructions in this manual can result in unreasonable exposure to hazardous conditions and/or personal injury and/or death.

Throughout this manual there are a number of HAZARD WARNINGS that must be read and observed to prevent possible loss of equipment and/or personal injury and loss of life. The three advisory words are "DANGER", "WARNING" and "CAUTION". They are used to indicate the severity of the hazard and are preceded by a safety alert symbol. 

### **DANGER**

**DANGER:** Denotes the most serious injury hazard and is used when serious injury or death **WILL** result from misuse or failure to follow the specific instructions set forth in this manual.

### **WARNING**

**WARNING:** Denotes when serious injury or death **MAY** result from misuse or failure to follow the specific instructions set forth in this manual.

### **CAUTION**

**CAUTION:** Denotes when injury, product or equipment damage may result from the misuse or failure to follow the specific instructions set forth in this manual.

It is the responsibility of personnel involved in the installation, operation and maintenance of the equipment, on which the HCC is mounted, to fully understand the warnings and dangers that are listed in this manual and to be aware and follow the correct procedures to safely install, operate, and maintain this equipment.

# Specifications/ Maintenance

## 2.0 SPECIFICATIONS

- 2.1 Ambient Temperature Range: -10 F [-25 C] to 110 F [43 C]
- 2.2 Voltage: Depending on the specific model, either 12 VDC or 24 VDC. 12 VDC versions should not be used with 24 VDC, and vice versa.
- 2.3 Pressure: Designed to deliver 500 PSI [35 bar] to the PTO.
- 2.4 Oil Type: Mobil 1 Synthetic ATF; Alternate Valvoline MaxLife ATF may be used. Reservoir capacity is 14 fl oz (410 cc).
- 2.5 Hydraulic Connection: SAE -4 port (J1926-1), Thread size is 7/16-20 UNF-2B (ANSI B1.1 / ISO 263) port to PTO.
- 2.6 Engine speed range to begin engagement:
  - Minimum: 600 r/min
  - Maximum: 1100 r/min

## 3.0 MAINTENANCE

- 3.1 Remove connection to the power supply before performing any maintenance.
- 3.2 Oil Level
  - 3.2.1 Maintain oil level at all times. Verify that the class of oil is as specified. Check the oil after the first 100 hours of operation. Change the oil every 1000 to 2000 hours of operation, depending on the operating environment, at least annually.
  - 3.2.2 The oil level can be seen through a rectangular opening near the bottom of the left side of the enclosure. See DRAWINGS section of this manual.
  - 3.2.3 Remove the enclosure and fill the reservoir as required. Re-install cover.
- 3.3 Inspect all hoses, fittings and connections periodically for leaks. Correct as necessary.

## 4.0 INSPECTION

- 4.1 Upon receipt of the HCC, inspect for and report any evidence of damage, especially to the connectors, wiring, and hydraulic connection.

# Installation

## 5.0 INSTALLATION

- 5.1 Use the provided mounting bolt locations to secure the HCC to the machine. See DRAWINGS section of this manual, for mounting locations.
- 5.2 Fill reservoir with Mobil 1 Synthetic ATF.
- 5.3 Remove plug, (item 12-see page 15), this SAE -4 port (J1926-1), 7/16-20 UNF-2B (ANSI B1.1 / ISO 263) will be the connection point to connect the PTO to Oil Supply/Return.
- 5.4 Electrical connection is made using Deutsch plugs. See INTERNAL WIRING DIAGRAM section of this manual.
- 5.5 Confirm that engine speed LED is solid green when engine is in engagement speed range.

NOTE: The hydraulic pump motor draws significant current. Its power should be supplied through a power relay contact as shown in the wiring diagram, rather than through the machine key switch.

- 5.6 Bleed Air from the System
  - 5.6.1 Follow the DISASSEMBLY procedure in this manual to remove the enclosure cover and expose the hydraulic pump assembly.
  - 5.6.2 Disconnect the electrical connector of the pressure transducer inside the enclosure.
  - 5.6.3 Remove fill cap on the reservoir and fill to "Max Line" with specified oil.
  - 5.6.4 Disconnect the hydraulic hose from the PTO, if connected.
  - 5.6.5 Hold the open end of the hydraulic hose over the reservoir fill spout to allow the fluid to flow back into the system.

### **WARNING**

- 5.6.6 Turn the system power (key switch) ON. Note: Do NOT start engine.

### **CAUTION**

- 5.6.7 Press and hold the engage switch. After 5 seconds the motor will turn on and stay on as long as the switch is held. (Note: Do not operate the motor continuously for more than 15 seconds.)
- 5.6.8 Monitor the oil returning to the reservoir. When the oil flow is continuous release the engage switch.
- 5.6.9 Turn the system power (key switch) "OFF".
- 5.6.10 Attach the hydraulic hose to the PTO.
- 5.6.11 Check the fluid level in the reservoir and ensure that it is at the "Max Fill Line". If not, add appropriate amount of fluid.
- 5.6.12 Re-install reservoir cap.
- 5.6.13 Re-attach pressure transducer electrical connector.
- 5.6.14 Re-install the enclosure cover.

NOTE: The first 5 to 15 engagements may seem inconsistent as the system stabilizes.

- 5.7 Contact WPT Power Application Engineering for technical support with hoses, mounting, customer electrical connections, and other questions, if retrofitting a HCC to an existing machine.

# Operation/ Disassembly

---

## 6.0 OPERATION

- 6.1 The first engagement of each day may take up to 30 seconds to complete. After this, the oil supply line and PTO should be fully charged with oil and subsequent engagements will occur more rapidly.
- 6.2 **START:** Press and hold the engage switch for 3 seconds. Engagement process will begin. Release the switch.
- 6.3 **STOP:** Press engage switch momentarily.
- 6.4 Refer to the machine manufacturer instructions if the HCC does not have an engage switch. The manufacturer can operate the HCC with their own switch or with CAN BUS commands.

## 7.0 DISASSEMBLY

- 7.1 Disconnect power to the machine while performing operations on the HCC.
- 7.2 Remove the three bolts that hold the HCC bracket in place.
- 7.3 Remove components, as necessary.

# Adjustment

## 8.0 ADJUSTMENT OF ENGAGEMENT SEQUENCE

- 8.1 The HCC is set up at the factory to operate with most engines and machines. However, variations in manufacturers, machines, and environmental conditions may require adjustment of the engagement sequence to provide the smoothest start.

The following steps outline how to adjust the HCC. This is a procedure that should not be required often.

- 8.2 Disconnect the two electrical connections from the control module (see Figure 1).
- 8.3 Using a flathead screwdriver, remove the control board from its plastic housing. This is accomplished by pressing the tabs inward toward the control board with the screwdriver while gently pulling out (see Figure 2). Use caution in this step to avoid damaging the control module.
- 8.4 Adjust the engagement of the HCC with a very small flathead screwdriver.
  - 8.4.1 If the clutch is engaging too quickly and engine is stalling when the clutch first plates are first in contact, turn the top-hand dial labeled “C” for contact speed (see Figure 3) counter-clockwise one number. If the clutch is engaging too slowly (longer than 7 seconds to contact) turn the dial clockwise one number.
    - “3” is a typical factory setting for the “C” dial.
  - 8.4.2 If the engine stalls after the clutch plates are first in contact and as the clutch engagement is increasing, turn the bottom-hand dial labeled “S” for seat speed (see Figure 3) counter-clockwise one number. If the clutch is engaging too slowly (longer than 10 seconds to complete engagement) turn the right-hand dial clockwise one number.
    - “2” is a typical factory setting for the “S” dial.

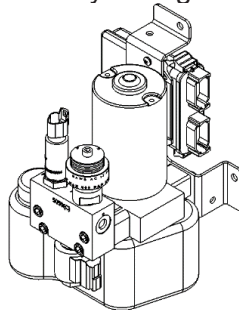

Figure 1: Two electrical connections for control module. Picture may vary depending on HCC options

# Adjustment

## 8.5 Configuration

- 8.5.1 Format USB stick to FAT32.
- 8.5.2 Copy the Configuration file (ex. SETTINGS(0000-0000-0000-0000).bin) from the PC to the USB stick.
- 8.5.3 Rename the config file saved on the USB stick to SETTINGS.BIN.
- 8.5.4 Eject the USB stick from the PC.
- 8.5.5 Remove power from the Printed Circuit Board (PCB).
- 8.5.6 While pressing and holding the CONFIG button on the PCB, apply power to the PCB.
- 8.5.7 Indicator D19 light will now be GREEN indicating bootloader operation. Release CONFIG button.
- 8.5.8 Plug the USB Stick into J2 on the PCB.
- 8.5.9 If SETTINGS.BIN file is found, D19 will now flash RED, indicating configuration update in process.
- 8.5.10 Update process should only take a few seconds. D19 will flash RED/AMBER until the process is complete, then the light will turn off.
- 8.5.11 Remove power from the PCB then remove the USB Stick.
- 8.5.12 Configuration Update is now complete.

Note: D19 light flash configuration as follows:

- Firmware and Settings:  
Red, Orange, OFF
- Firmware ONLY:  
Red, OFF
- Settings ONLY:  
Red, Orange, ON

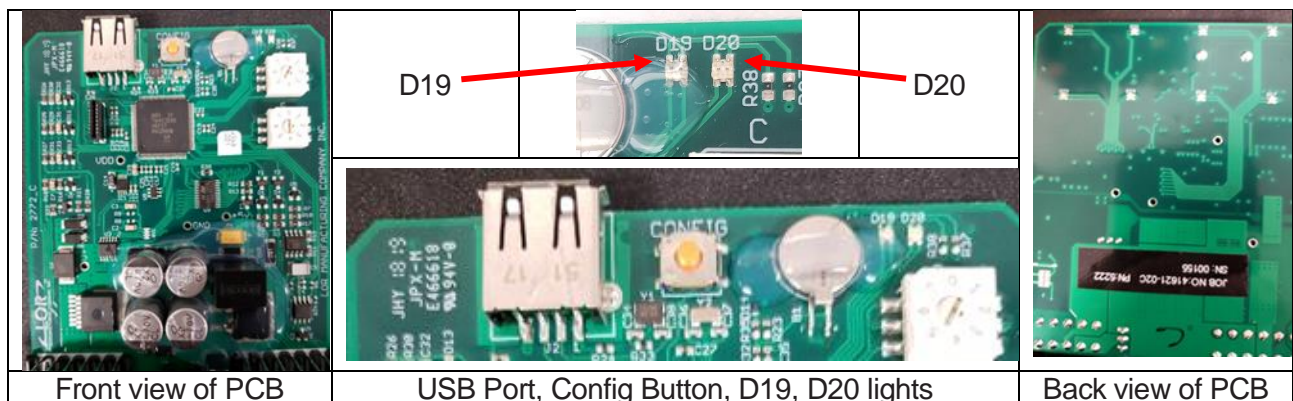



# Adjustment

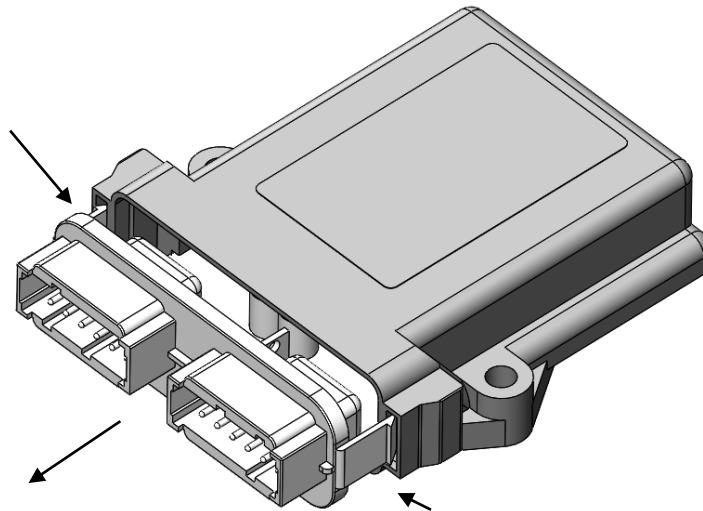

Figure 2: Remove the control board from its plastic housing by pressing in the tabs and pulling out.

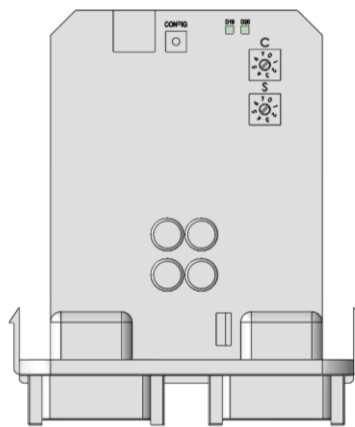

Figure 3: Adjustment of the contact speed using the top-hand "C" dial. Adjustment of the seat speed using the bottom-hand "S" dial. Counter-clockwise slows the engagement, clockwise speeds it up.

## 9.0 ASSEMBLY

- 9.1 Install components as necessary.
- 9.2 Install the three bolts that hold the HCC bracket in place.
- 9.3 Connect power to the machine while performing operations on the HCC.

# Graphic Overlay

## 10.0 GRAPHIC OVERLAY

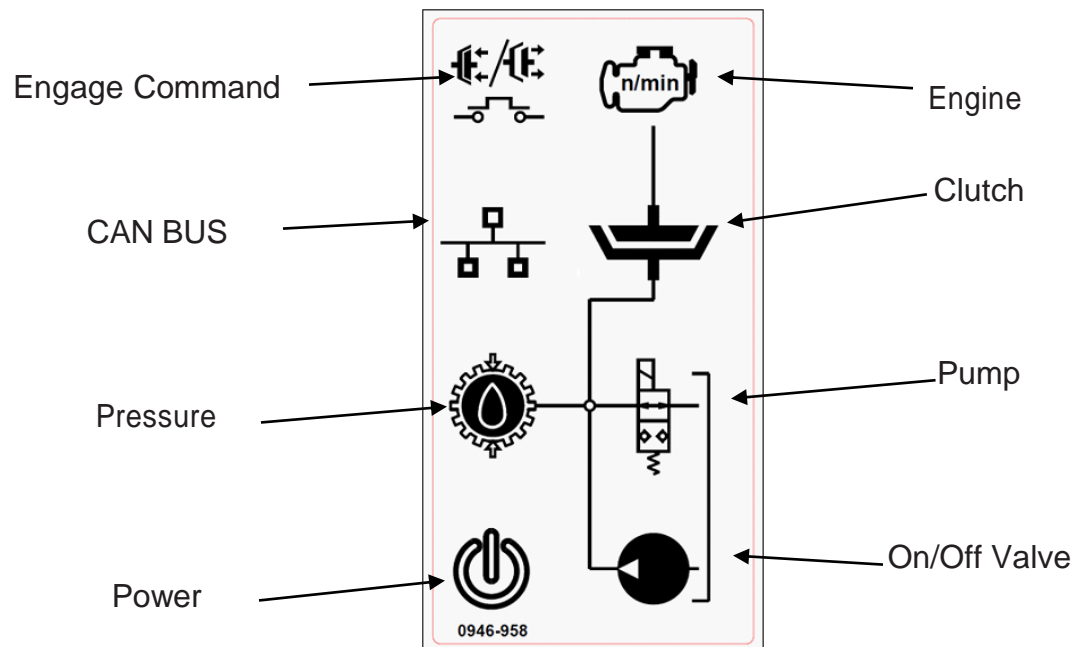

## HYDRAULIC CLUTCH CONTROL

- 10.1 The HCC graphic icon Green and Red states are OFF, Solid (ON), or flashing, with equal ON and OFF times, at one of two rates:
  - 10.1.1 Slow is four flashes per second.
  - 10.1.2 Fast is eight flashes per second.
- 10.2 Pressing the Engage switch or sending the CAN BUS Engage command resets alarm conditions and indications.

# Graphic Overlay

## 10.3 ENGAGE SWITCH (Optional)

- 10.3.1 Push and hold switch to engage the clutch. Release after 3 seconds.
- 10.3.2 Push and hold for 1 second to disengage the clutch.
- 10.3.3 LED OFF - Clutch is disengaged or no power to controller
- 10.3.4 LED Slow - Clutch is engaging, one flash per second
- 10.3.5 LED Solid - Clutch is engaged

## 10.4 POWER Icon



- 10.4.1 OFF - No power to controller
- 10.4.2 Green Solid - Operational voltage normal
- 10.4.3 Red Solid - Operational voltage above normal

## 10.5 PRESSURE Icon



- 10.5.1 OFF - No hydraulic pressure detected
- 10.5.2 Green Solid - Pressure within operational range
- 10.5.3 Green Slow - Pump has run briefly 3 or more times in 10 minutes while clutch is engaged. The following occurs.
  - 10.5.4 Green Fast - Pressure exceeds 575 PSI after engagement.
  - 10.5.5 Red Solid - Pressure above or below operational range
  - 10.5.6 Red Slow - Pressure transducer signal low error
  - 10.5.7 Red Fast - Pressure transducer signal high error
  - 10.5.8 Red/Green Alternating - Engagement process was halted due to inability to build or recover pressure in 10 seconds. Possible causes are pump not turning/stalled, leaks, or low oil. The following occurs.
    - 8.5.8.1 Strobe output to customer alarm is Solid ON
    - 8.5.8.2 Clutch disengages, if engaged
    - 8.5.8.3 Clutch Icon flashes Red Slow

# Graphic Overlay

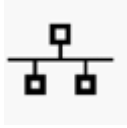

## 10.6 **CAN BUS Icon** (network connection)

- 10.6.1 OFF - CAN BUS not detected. Does not mean communication, only that power is present.
- 10.6.2 Green Slow - CAN BUS has been detected but has gone idle, not receiving any CAN messages. Check for intermittent connections on the CAN line and that all modules (engine ECM, master controller, etc.) are powered.
- 10.6.3 Green Fast - Message errors have been detected on the CAN BUS. Possible causes: improper CAN BUS termination, excessive stub drop length, excessive overall CAN BUS length.
- 10.6.4 Red Solid - CAN BUS OFF. Enough errors on the BUS will halt all transmissions on the CAN. Possible causes, shorted CAN wires.
- 10.6.5 Red Slow - CAN Chip on controller did not pass initialization.



## 10.7 **ENGAGE COMMAND Icon**

- 10.7.1 OFF - Switch or CAN bus engage command not detected
- 10.7.2 Green Solid - Engage command detected
- 10.7.3 Red Solid - Disengage command detected
- 10.7.4 Red Slow - Clutch disabled by external disengage/stop input

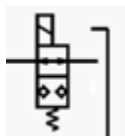

## 10.8 **PUMP Icon** flash patterns indicate percentage of drive output to pump motor. The pump will turn on and off several times during normal engagement, and it can be difficult to tell whether the lights are flashing, or the pump is actually ON and OFF.

- 10.8.1 OFF - Output to pump motor is OFF
- 10.8.2 Green Slow - Pump speed between 30 and 59%
- 10.8.3 Green Fast - Pump speed between 60 and 100%
- 10.8.4 Red Solid - Pump speed between 1 and 9%
- 10.8.5 Red Slow - Pump speed between 10 and 19%
- 10.8.6 Red Fast - Pump speed between 20 and 29%

# Graphic Overlay



## 10.9 **ON/OFF VALVE** Icon

- 10.9.1 OFF - Output to valve coil is OFF
- 10.9.2 Green Solid - Output is ON and operational
- 10.9.3 Red Solid - Open load detected, possibly valve coil, wiring, or output
- 10.9.4 Red Fast - Overload detected, possibly valve coil, wiring, or output



## 10.10 **CLUTCH** Icon

- 10.10.1 OFF - Clutch is disengaged
- 10.10.2 Green Solid - Clutch is engaged
- 10.10.3 Green Slow - Clutch is in engagement process
- 10.10.4 Red Solid - Clutch disengaged due to overload condition
  - Strobe output to customer alarm is Solid ON
- 10.10.5 Red Slow - Clutch disengaged due to loss of pressure



## 10.11 **ENGINE** Icon indicates that the input speed to the clutch is within correct operating range to allow engagement.

- 10.11.1 OFF - No input speed detected
- 10.11.2 Green Solid - Input speed detected and within operational range
- 10.11.3 Red Solid - Input speed detected, but below or above operational range

# Troubleshooting Guide

Problem	Possible Cause	Remedy
Engagement does not begin	Engage Command LED does not come on when CAN bus engage command is sent	Power Off, retry. Try with engage switch
	Control condition not met	Determine condition from graphic icons
	Initialization not complete	Allow initialization to complete
	Engine speed too high or too low	Adjust engine speed until engine LED is green before engagement
	Engage switch was pressed when engine was started	Release and press engage switch again
	Faulty connector	Check all connectors for proper seating and damage
	Faulty wiring	Check all wiring for frays, cuts and tears.
Engagement begins, but fails	Control condition not met	Determine condition from graphic icons
	Engine nearly stalls	Increase engine speed before Engagement Adjust control module dials if repetitive
	Equipment jammed	Clear jam
	Physical safety lockout installed	Remove
	Faulty connector	Check all connectors for proper seating and damage
	Faulty wiring	Check all wiring for frays, cuts and tears
Engagement is not smooth	Engine speed too high	Reduce engine speed before engagement
	Extreme cold weather	Allow machine to warm up properly before use
	Oil supply inconsistent	Check for leaks
PTO kicks out when increasing engine speed	Overspeed	Try to increase engine speed slowly, contact factory
Other		Contact factory for assistance

# Assembly Drawing & Parts List

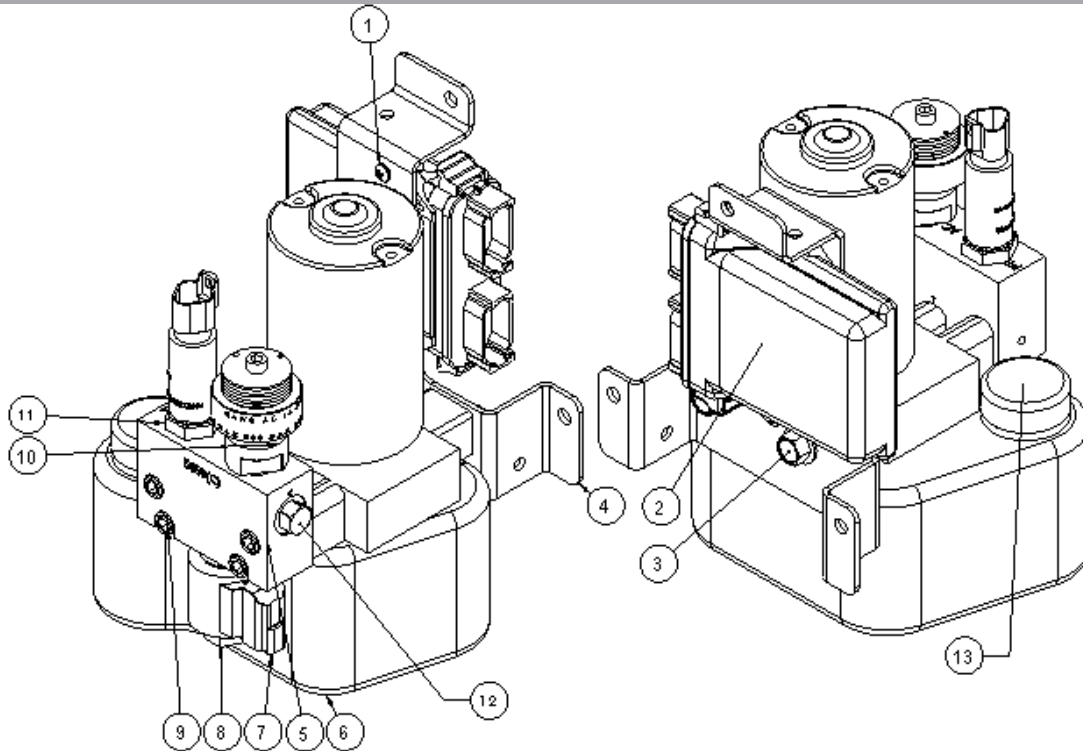

ITEM #	PART #	DESCRIPTION	QTY 12V	QTY 24V
1	WEX2502458	SCREW,10-32 X 5/8 STAINLESS	2	2
2	WRS-98-007	MODULE, CONTROL, HYDRAULIC CLUTCH CONTROL	1	1
3	WEX2008037	HHCS 3/8-16 X 5/8	2	2
4	WRS-90-047	BRACKET,MOUNTING ,HYDRAULIC CLUTCH CONTROL	1	1
5	WRS-90-046	ALUMINUM HYDRAULIC BLOCK	1	1
6	WRS-90-048	PUMP,HYDRAULIC , 12V DC, LOW VOLUME, PARKER OILDYNE	1	0
6	WRS-90-051	PUMP,HYDRAULIC , 24V DC, LOW VOLUME, PARKER OILDYNE	0	1
7	WRS-90-045	SOLENOID, 12 VDC, W/ ZENER DIODE	1	0
7	WRS-90-052	SOLENOID, 24 VDC, W/ ZENER DIODE	0	1
8	WRS-90-044	VALVE,PROPORTIONAL RELIEF	1	1
9	WEX2005926	SHCS 5/16-24 X 1-1/2	4	4
10	WRS-90-018	ACCUMULATOR,CONTROL,CLUTCH, HYDRAULIC	1	1
11	WRS-90-007	PRESSURE TRANSMITTER TDH43KG0600009X3005	1	1
12	WRS-90-053	PLUG,SAE-4(J 1926-1) 7/16"-20 WITH O RING	1	1
13	WRS-90-050	CAP, RESERVOIR, HCC GEN II & III	0	0
	WRS-90-038	WIRING HARNESS (NOT SHOWN)	1	1

# Drawings

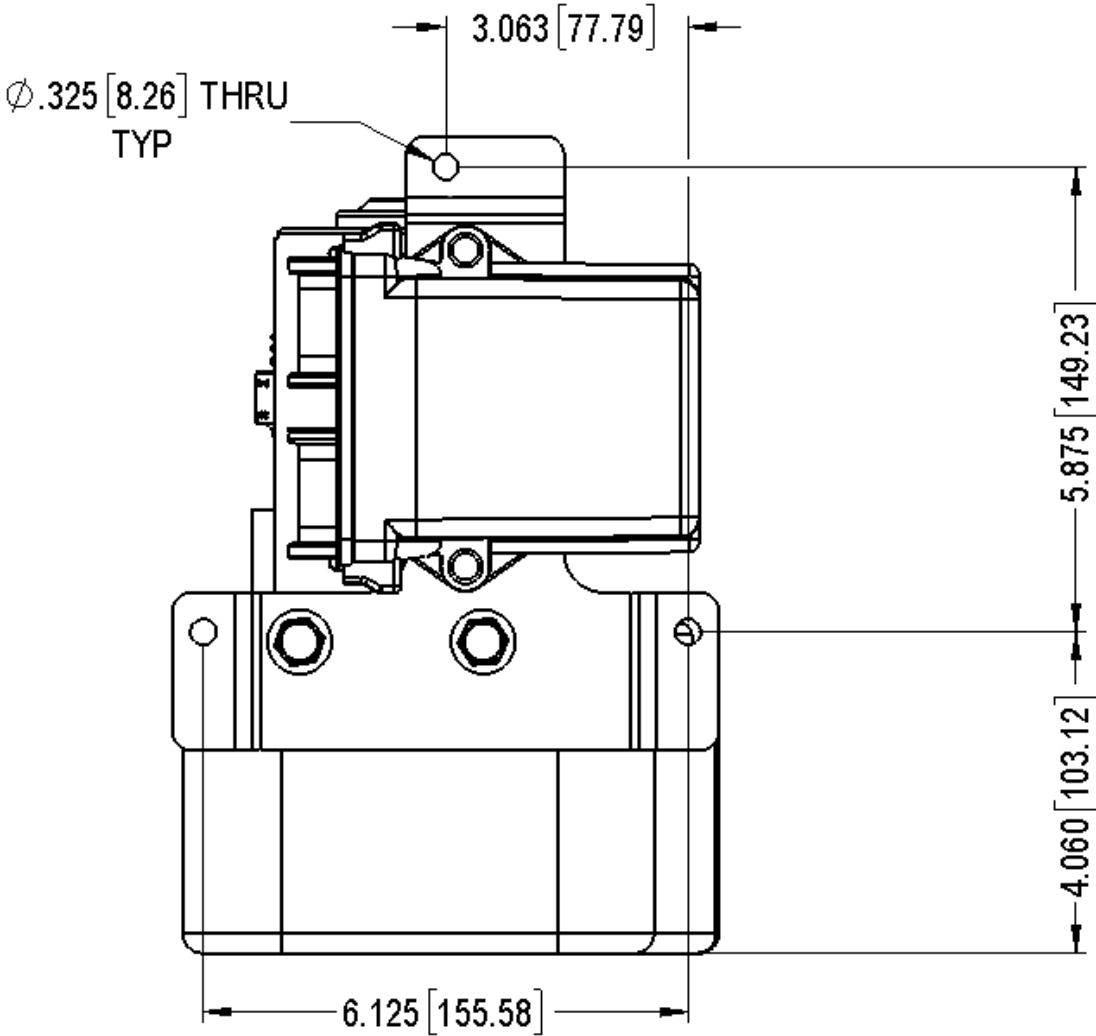

Mounting location



# Wiring Diagram (Internal Harness)

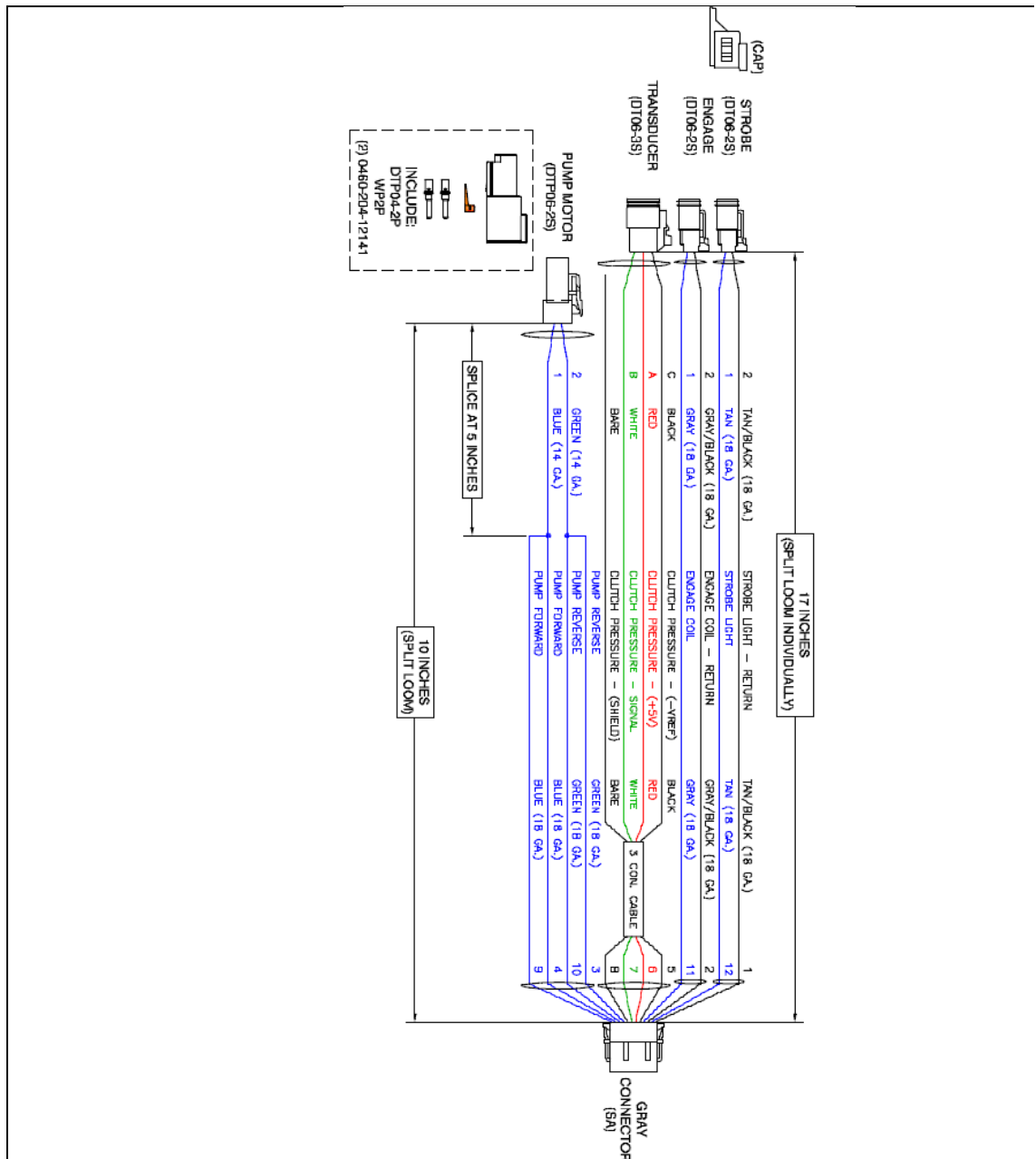

# Python Wiring Integration for Customer

## Equipment follows SAE J1939 Standards

### Black Deutsch DTM06 12S-pin plug Pinout:

- B01: Positive voltage from machine (required)
- B02: Positive voltage from machine (required)
- B03: Engine switch LED (Not Required)
- B04: Engine switch open (Not Required)
- B05: Frequency Input (Not used on ECU controlled engines)
- B06: Can Low (required)
- B07: Can High (required)
- B08: STOP - needs V+ feed when machine/engine safety stop is activated (optional)
- B09: V+ for common power source (output) (optional)
- B10: V+ for common power source (output) (optional)
- B11: Ground from machine (required)
- B12: Ground from machine (required)

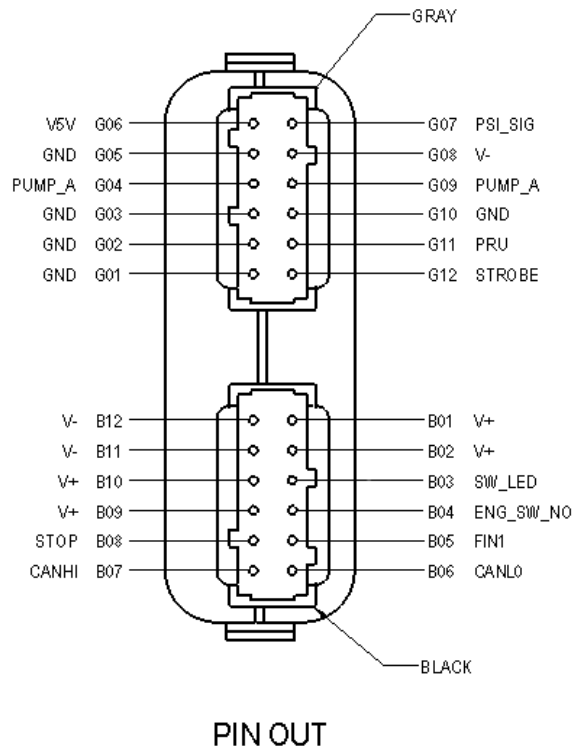



**WPT Power Corporation**

**1600 Fischer Road – Wichita Falls, Tx 76305**

**P.O. Box 8148 – Wichita Falls, Tx 76307**

**Ph. 940-761-1971**

**[www.WPTpower.com](http://www.WPTpower.com)**