

INDUSTRIAL CALIPER BRAKE

SILICON BRONZE VERSION
INSTALLATION AND MAINTENANCE MANUAL

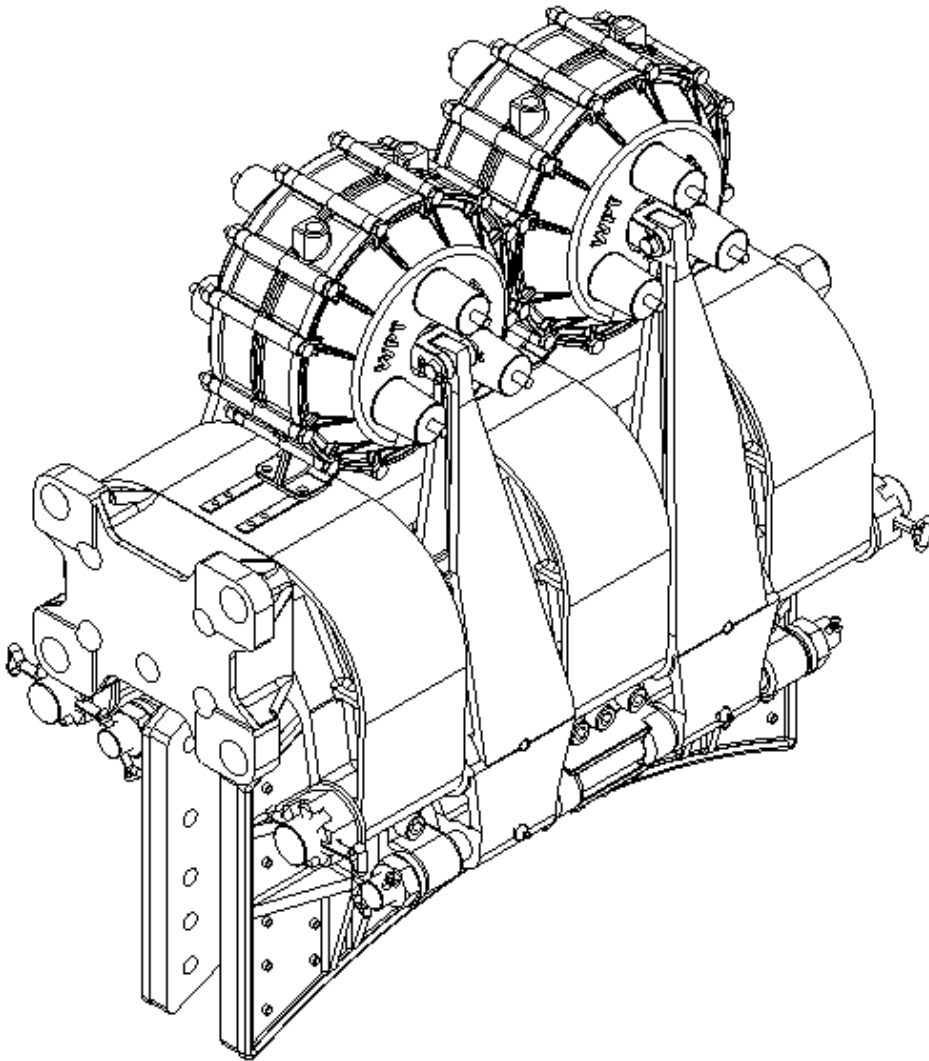

Table of Contents

Page No.

1.0 INTRODUCTION	4
1.1 WPT Power PTO	
1.2 Product identification numbers	
1.3 Bill of materials	
2.0 SPECIFICATIONS	5
2.1 Brake rotor disc specifications	
2.2 Brake disc mounting hole clearance	
2.3 Brake disc pilot clearance	
2.4 Maximum RPM	
2.5 Brake disc alignment tolerances	
2.6 Protective cover design	
2.7 Bolt torque values	
3.0 INSPECTION	6
3.1 Preparation	
3.2 Brake rotor disc face run out inspection	
3.3 Shaft bearing endplay inspection	
4.0 INSTALLATION	7
4.1 Preparation	
4.2 Brake disc expansion	
4.3 Brake disc installation	
4.4 Caliper installation	
4.5 Drawing and parts list reference	
4.6 Caliper clearance adjustment	
4.7 Air lines	
4.8 Protective cover design	
5.0 LUBRICATION	7
5.1 Grease lubrication	
5.2 Oil lubrication	
5.3 Drawing and parts list reference	
6.0 OPERATION	8
6.1 Clearance inspection	
6.2 Burnish friction linings	
6.3 Disc warm up in cold weather	
6.4 Air applied/spring release actuator	
7.0 MAINTENANCE	8
7.1 <u>Air applied caliper brake</u>	
7.2 Clearance inspection	
7.3 Clearance adjustment	
7.4 Friction lining alignment	
7.5 Adjust friction alignment (balancing link)	
7.6 Periodic inspection	
7.7 Friction lining replacement	
7.8 Remove rivets	
7.9 Install shoe assembly	
7.10 Lubrication	

Table of Contents

Page No.

7.11	Adjust clearance	
7.12	Readjust clearance	
7.13	Clearance requirement	
7.14	Balancing link	
7.15	Periodic inspection	
7.16	Friction lining replacement	
7.17	Remove rivets	
7.18	Install shoe assembly	
7.19	Lubrication	
8.0	DISASSEMBLY10
8.1	Air applied caliper brake	
9.0	ASSEMBLY10
9.1	Air applied caliper brake	
9.2	Bolt Torque	
9.3	Brake adjustment	
10.0	CHART 1 BOLT TORQUE VALUES11
11.0	ACTUATOR ASSEMBLY - AIR APPLIED BRAKE12
12.0	AIR APPLIED BRAKE ASSEMBLY13
13.0	GENERAL STORAGE GUIDELINES14

1.0 INTRODUCTION

- 1.1 The WPT Power Industrial Caliper Brake is one of the finest available on the market today. Follow the procedures detailed in this Installation Maintenance Manual for years of service.
- 1.2 When ordering parts, use the part numbers from the Bill of Materials supplied with this unit. Also, please include the part number and the serial number from the unit itself. These will be found on the mounting bracket. Your WPT Distributor can provide a copy of the Bill of Materials if the one provided should become lost.
- 1.3 When performing installation and maintenance functions, refer to the drawings at the back of this manual, pages 12 thru 13. The references on the drawing in this manual DO NOT correspond to the references on the assembly drawing and Bill of Materials. Do not use the item numbers from the drawing in this manual for ordering parts.

 **DANGER:**

To avoid damage or personal injury, ensure that adequate lifting devices and hand tools are available.

 **DANGER:**

Read these instructions thoroughly and review until you fully understand all warning and hazards before proceeding with the work described in this manual. Failure to follow these instructions in this manual can result in unreasonable exposure to hazardous conditions and/or personal injury and/or death.

Throughout there are a number of HAZARD WARNINGS that must be read and adhered to in order to prevent possible loss of equipment and/or personal injury and/or loss of life. The three warning words are “DANGER”, “WARNING” and “CAUTION”. They are used to indicate the severity of the hazard and are preceded by a safety alert symbol. 

“**DANGER**” – Denotes the most serious injury hazard and is used when serious injury or death **WILL** result from misuse or failure to follow the specific instructions set forth in this manual.

“**WARNING**” – Denotes when serious injury or death **MAY** result from misuse or failure to follow the specific instructions set forth in this manual.

“**CAUTION**” – Denotes when injury or product or equipment damage may result from the misuse or failure to follow the specific instructions set forth in this manual.

It is the responsibility of the personnel involved in the installation, operation and maintenance of this equipment, on which this brake is mounted, that they must fully understand the warnings and dangers that are listed in this manual and are aware of what the correct procedures must be to safely install, operate and maintain this equipment.

2.0 SPECIFICATIONS

2.1 Brake Disc Rotor specifications.

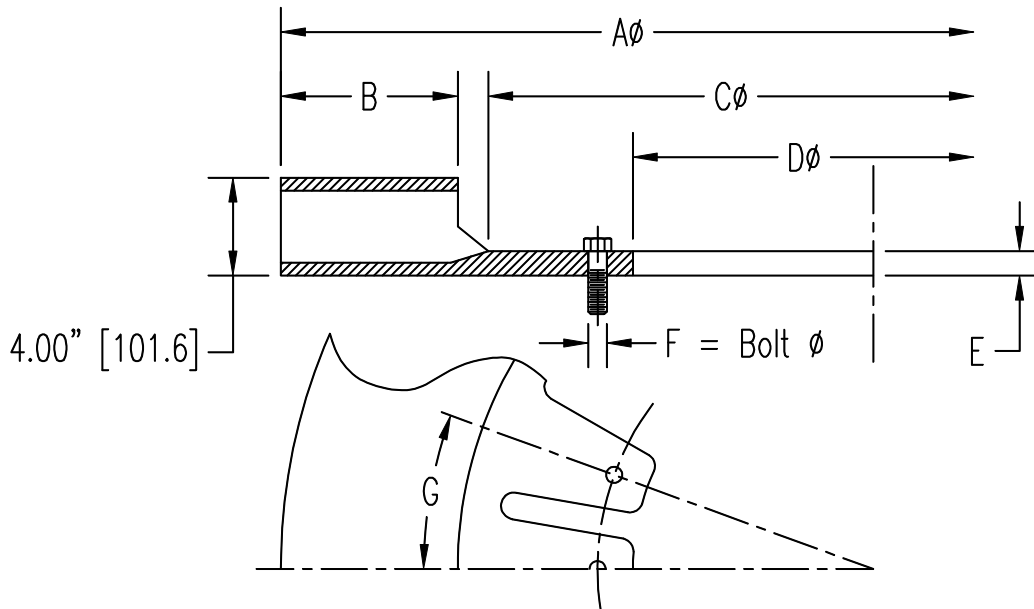

Caliper Size	WDA-26			WDA-28		
	A	30" [762]	40" [1016]	48.3" [1227]	48.5" [1232]	54.7" [1389]
B	7" [178]	7" [178]	7" [178]	10.5" [267]	10.5" [267]	10.5" [267]
C	14" [356]	23.7" [602]	31" [787]	24" [610]	32" [813]	37" [940]
D Min.	8" [203]	19.6" [498]	19.7" [500]	17.7" [450]	23.2" [589]	27.3" [693]
D Max.	11" [279]	21" [533]	28" [711]	22" [559]	28" [711]	32.5" [826]
E	.91" [23.1]	.95" [24.1]	1" [25.4]	.91" [23.1]	1" [25.4]	1.09" [27.7]
F Min.	5/8" or 16mm	5/8" or 16mm	5/8" or 16mm	5/8" or 16mm	1" or 24mm	1" or 24mm
G	30°	20°	20°	30°	18°	18°
Wt. Lbs. (Kg)	360 (163)	430 (195)	620 (281)	780 (354)	900 (408)	990 (449)
Max. RPM	1150	860	710	710	630	570

NOTE: All fasteners must be SAE Grade 8 or better.

- 2.2** When running at elevated temperatures, allow adequate mounting holes clearance for disc to expand and contract during operation. Contact WPT Power with all the operating data for assistance.
- 2.3** When running at elevated temperatures, allow adequate male to female pilot clearance for disc to expand and contract during operation. Brake rotor disc may also shrink and could become smaller depending on the maximum operating temperature. Contact WPT Power with all the operating data for assistance.
- 2.4** Brake disc maximum RPM, see section 2.1 on page 5.
- 2.5** Brake rotor disc alignment tolerances, see section 3.0.
- 2.6** In order for WPT's air cooled caliper brake to function properly, the protective cover must be designed to not restrict air flow to and from the disc rotor. The free flow of air is required to prevent overheating. Air pumped through the disc rotor must be exhausted away from the disc rotor to allow fresh cool air to enter.

⚠ CAUTION:

Under no circumstances should the disc rotor cooling fins be painted or shielded.

2.7 Recommended bolt torque values, see section **10.0 Chart 1** on page 11.

3.0 INSPECTION

3.1 **Preparation.** Upon receipt of your WPT product, inspect for and report any evidence of damage.

⚠ DANGER:

To avoid damage or personal injury, ensure that adequate lifting devices and hand tools are available.

3.2 **Check Brake Rotor Disc face run out.** It is strongly recommended that dial indicator checks be made prior to installation of the caliper brake. Mount the indicator base on the caliper mounting pad and position the dial indicator tip so that its movement is perpendicular to the face of the brake rotor disc. Position the indicator tip near the outside diameter of the brake rotor disc, see sketch below. Rotate the disc 360 degrees.

The indicator reading should not exceed 0.015 inches (0.38 mm) T.I.R.

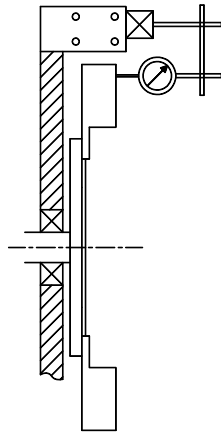

3.3 **Check Brake Rotor Disc Concentricity.** Mount the indicator base on the caliper mounting pad and position the dial indicator tip so that its movement is perpendicular to the brake rotor disc outside diameter. Rotate the disc 360 degrees.

The indicator reading should not exceed 0.030 inches (0.76 mm) T.I.R.

3.4 **Check bearing shaft endplay.**

Measure and document the shaft's endplay before installing the brake caliper. Using dial indicator as shown in 3.2 move the shaft back and forth axially against bearings. Endplay must be kept at a minimum. Record the total movement as shown by the dial indicator and keep for future reference.

4.0 INSTALLATION

- 4.1 Clean the friction surfaces of the brake rotor disc with an appropriate cleaning solvent to remove any oil and grease.
- 4.2 When installing a brake rotor disc that is running at elevated temperatures, it is important to allow for disc expansion and contraction, see section 2.0.



WARNING:

Failure to leave clearance for brake rotor disc expansion and contraction may result in premature failure.



DANGER:

The brake rotor disc and caliper brake are heavy. Use appropriate equipment and procedures to prevent accident or injury.

- 4.3 Mount brake rotor disc using grade 8 hex head cap screws or socket head cap screws. Tighten bolts evenly using a crisscross pattern. Torque bolts to the specifications in Chart 1 on page 11.
- 4.4 Mount caliper brake using grade 8 hex head cap screws or socket head cap screws. Torque bolts evenly to the specifications in Chart 1 on page 11. Check to insure proper clearance between O.D. of the disc rotor and the inner caliper brake frame.

IMPORTANT: Mounting foot used to mount the caliper brake on must be flat and square to the disc rotor face and strong enough to withstand the maximum torque generated by the brake caliper.
- 4.5 Refer to caliper brake illustrations and parts lists in the back of this manual, pages 12 thru 13.
- 4.6 For initial adjustment of caliper brake: See adjustment instruction in 7.0.
- 4.7 Air lines to the actuators should be sufficient size to allow quick response of the brake.
- 4.8 When installing a protective cover, ensure that air recirculation through the disc is not restricted. Air pumped through the disc must be exhausted away from the disc to allow fresh cool air to enter the inner vent openings of the disc. Back pressure should not be generated on the exhaust side of the disc.

5.0 LUBRICATION



CAUTION:

Protective means must be used to prevent oil or grease from coming in contact with friction linings or the brake rotor disc. Contamination of the friction linings could result in erratic response and/or loss of torque.

- 5.1 If caliper brake has grease zerks, apply grease approximately every 100 hours of use to all grease fittings. Use a good quality lithium-based grease (300°F minimum drop point, No. 2 NGLI).
- 5.2 If caliper brake does not have grease zerks, apply a small amount good quality oil to the saddle rod connections and shoe rod connections to prevent wear and corrosion.
- 5.3 Refer to caliper brake illustrations and parts lists in the back of this manual, pages 12 and 13.

6.0 OPERATION

- 6.1 Check to ensure friction linings do not contact the disc rotor when disengaged and are square to the disc rotor. The clearance should be equally divided on both sides of the disc rotor.

IMPORTANT: Friction linings must be burnished in order to achieve maximum brake torque.

- 6.2 Burnishing can be accomplished by engaging the caliper brake, using low air pressure, approximately three times for 10 to 15 minutes.

NOTE: On some equipment it may not be possible to burnish the linings because of slow rotating speed and/or limited HP available.

- 6.3 In cold weather it is important to warm the disc rotor slowly to not cause excessive thermal stresses in the disc rotor.

WARNING:

Failure to warm the disc rotor slowly may cause instant disc failure.

- 6.4 WPT provides an air applied/spring release actuator, see illustrations and parts list pages 12 and 13.

WARNING:

Do not apply the spring side and the air side at the same time. This could cause an overload on the brake structure.

7.0 MAINTENANCE

WARNING:

Turn off engine and prevent from being restarted while adjustments are being performed.

IMPORTANT: Before making any adjustment, ensure that the brake is released.

- 7.1 **Air set style caliper brakes** do not require adjustment for clearance after installation. Refer to illustrations and parts list pages 12 and 13.
- 7.2 Set the distance between friction linings to 4.06"/4.13" [103.12/104.90] before mounting the brake.
- 7.3 To adjust the distance between friction linings, remove **cotter pins (2)**, **lever pins (1)** and turn both **clevis pins (27)** an equal amount. Turn counterclockwise to decrease clearance and clockwise to increase clearance.
- 7.4 **Friction linings (29 & 31)** must be parallel to brake disc rotor to ensure even lining wear.
- 7.5 To adjust alignment, loosen **SHCS (35)** and adjust **balancing links (33 & 36)** to align the **shoes (28 & 30)** parallel with the disc.
- 7.6 **Periodic inspection** should be performed for wear of **friction linings (29 & 31)**.
IMPORTANT: Friction linings must be replaced before rivets contact the disc rotor.
- 7.7 **Replace friction lining (29 & 31)** by removing **cotter pins (13)**, **nuts (11)** and **shoe rod (10)** holding shoe assembly to the lever. Remove **bolts (18)** holding **outer bearing (19)** and **center bearing (20)** to the shoe assembly.

- 7.8** Drill out the **rivets (32)** and install new **friction linings (29 & 31)** with rivets or bolts.
- If bolts are used see detail below.

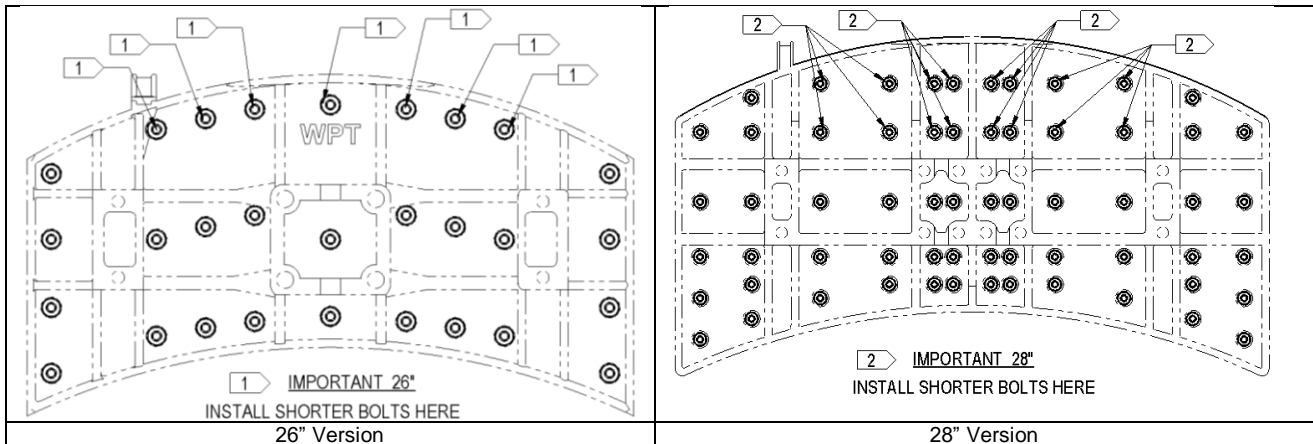

- 7.9** Install shoe assembly to the caliper assembly by reversing **steps 7.7 & 7.8** above. Be sure to re-engage the **balancing link (33 & 36)**. To adjust alignment, **see 7.5**.

- 7.10** Lubrication should be performed periodically, see 5.0 for instructions

- 7.11** To adjust the clearance between the disc rotor and **friction linings (4)**, adjust the **nuts (A & B)** on **rod (25)** up and down to move **spreader (31)** to a position that gives the correct clearance.

- 7.12** Clearance must be readjusted as friction lining wears. For optimum performance, it is essential that the clearance be kept at a minimum without causing drag. Springs extend and become weaker as the friction linings wear, causing brake torque to decrease.

⚠ WARNING:

Failure to adjust the spreader (31) down as friction linings wear may result in brake failure as there is not enough movement to apply the brake shoe to against the disc.

- 7.13** **Periodic inspection** should be performed for proper clearance and wear of **friction linings (4)**.

IMPORTANT: Friction linings must be replaced before rivets (hardware) contact the disc rotor.

- 7.14** **Replace friction lining (4)** by removing **cotter pins (23)**, **nuts (15)** and **shoe rod (14)** holding shoe assembly to the lever. Remove **bolts (20 & 21)** holding **outer bearing (22)** and **center bearing (19)** to the shoe assembly.

- 7.15** Drill out the **rivets (18)** and install new **friction linings (4)** with rivets or screws.

- 7.16** Install shoe assembly to the caliper assembly by reversing **steps 7.12 & 7.13** above. Be sure to re-engage the **balancing link (3)**.

- 7.17** Lubrication should be performed periodically, see 5.0 for instructions.

8.0 DISASSEMBLY



DANGER:

Use a hoist or other suitable lifting equipment to support the weight of the caliper brake and disc rotor.



DANGER:

The caliper brake and disc rotor are heavy. Use approved lifting eyes and procedures to prevent accident or injury.



WARNING:

Use care when removing the caliper brake from the disc rotor to avoid damage to grease fittings, shoe assemblies and any other components.

8.1 Air set caliper brakes, refer to caliper brake illustrations on page 13.

- 8.1.1 Remove any air lines and bolts holding caliper brake to frame. Lift caliper brake and place on work bench.
- 8.1.2 Remove **cotter pins (2)**, **lever pins (1)** and **bolts (26)** holding actuator assembly to caliper brake.
- 8.1.3 Remove **cotter pins (13)**, **nuts (11)** and **shoe rod (10)** holding shoe assembly to the levers. Remove **bolts (18)** holding **outer bearing (19)** and **center bearing (20)** to the shoe assembly.
- 8.1.4 Remove **cotter pins (9)**, **nuts (7)** and **saddle rod (6)** holding levers to the caliper brake.
- 8.1.5 Remove **tie rod nuts (4)** and **lock washers (5)** from tie rods.
- 8.1.6 Remove **saddles (15)** and **spacers (16)** from tie rods.
- 8.1.7 Remove **tie rods (3)** from **mounting foot (25)**.
- 8.1.8 **Disassemble actuator assembly (14)**, refer to actuator assembly illustrations on page 13.
- 8.1.9 **IMPORTANT:** Retain **end caps (1)** with an adjustable clamp before removing **bolts (8)** and **nuts (9)**. Internal springs are under compression and must be retained.
- 8.1.10 Remove **nuts (9)** and **bolts (8)** from actuator assembly. Then slowly release spring pressure with clamp until all pressure is relieved.
- 8.1.11 Slide **end caps (1)** off of **guide pins (3)** and separate the other parts.
- 8.1.12 Inspect parts for wear or damage and replace as necessary.

9.0 ASSEMBLY

- 9.1 **Air set caliper brakes** by reversing steps in 8.1.
- 9.2 Torque bolts to the requirements specified in **chart 1**, page 11.
- 9.3 Adjust caliper brake as indicated in instructions 7.0, on page 8.

10.0 CHART 1

TORQUE VALUES FOR SOCKET HEAD AND HEX HEAD CAPSCREWS						
SOCKET HEAD CAP SCREWS						
BOLT SIZE IN INCHES	As Received			Lubricated**		
	LB - FT	LB - IN	Nm	LB - FT	LB - IN	Nm
1/4	13	150	17	10	120	13
5/16	23	305	34	18	244	27
3/8	45	545	62	36	436	49
7/16	70	840	95	56	672	76
1/2	108	1300	147	86	1040	117
9/16	155	1860	210	124	1488	168
5/8	211	2530	286	168	2024	228
3/4	367	4400	497	293	3520	397
7/8	583	7000	791	466	5600	632
1	867	10400	1175	693	8320	940
1 1/8	1242	14900	1684	993	11920	1347
1 1/4	1750	21000	2374	1400	16800	1899
1 3/8	2317	27800	3142	1853	22240	2513
1 1/2	3042	36500	4125	2433	29200	3300
1 3/4	4950	59400	6714	3960	47520	5371
2	7492	89900	10161	5993	71920	8128
HEX HEAD CAP SCREWS - Grade 8						
BOLT SIZE IN INCHES	As Received			Lubricated**		
	LB - FT	LB - IN	Nm	LB - FT	LB - IN	Nm
1/4	8	100	11	6	80	9
5/16	17	200	23	13	160	18
3/8	30	360	41	24	288	32
7/16	48	570	64	38	456	51
1/2	83	990	112	66	792	89
9/16	107	1285	145	85	1028	116
5/8	143	1714	194	114	1371	155
3/4	256	3070	347	204	2456	277
7/8	417	5000	565	333	4000	452
1	625	7500	848	500	6000	678
HEX HEAD CAP SCREWS - Grade 5						
BOLT SIZE IN INCHES	As Received			Lubricated**		
	LB - FT	LB - IN	Nm	LB - FT	LB - IN	Nm
1/4	6	71	8	5	56	6
5/16	12	142	16	9	113	12
3/8	22	260	29	17	208	23
7/16	34	410	46	27	328	36
1/2	53	636	72	42	508	57
9/16	74	890	101	59	712	80
5/8	104	1250	141	83	1000	112
3/4	183	2200	249	146	1760	199
7/8	298	3570	403	238	2856	322
1	440	5280	597	352	4224	477
1 1/8	553	6640	750	442	5312	600
1 1/4	775	9300	1051	620	7440	840
1 3/8	1012	12140	1372	809	9712	1097
1 1/2	1350	16200	1831	1080	12960	1464

** NOTE: For Loctite use lubricated values

11.0 ACTUATOR ASSEMBLY DRAWING AND PARTS LIST

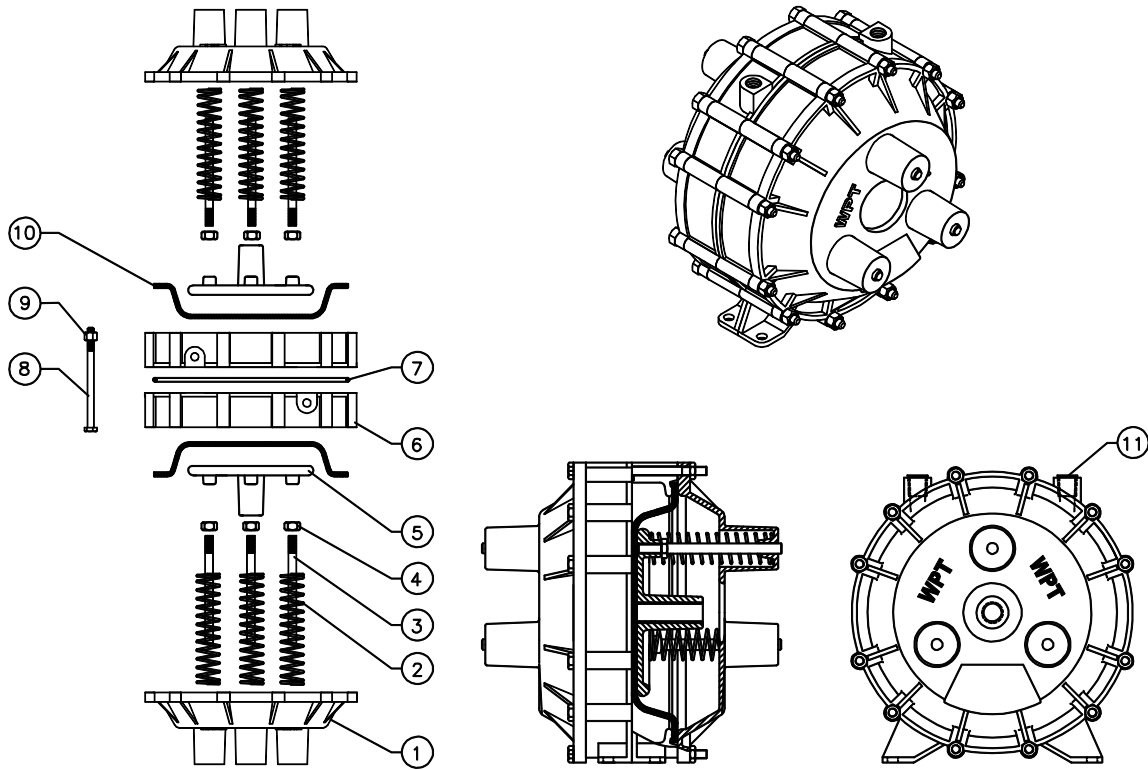

Item	Description	Qty	Item	Description	Qty
1	End Cap	2	7	"O" Ring	1
2	Spring	6	8	HHCS, Size WDA-26	8
3	Guide Pin	6	8	HHCS, Size WDA-28	12
4	Nut	6	9	Nut, Size WDA-26	8
5	Plate, Diaphragm	2	9	Nut, Size WDA-28	12
6	Housing	2	10	Diaphragm	2
			11	Plug	1

NOTE: For actual drawing and parts list, contact WPT. Use assembly no./serial no. to identify your unit.

12.0 CALIPER BRAKE, AIR APPLIED, DRAWING AND PARTS LIST

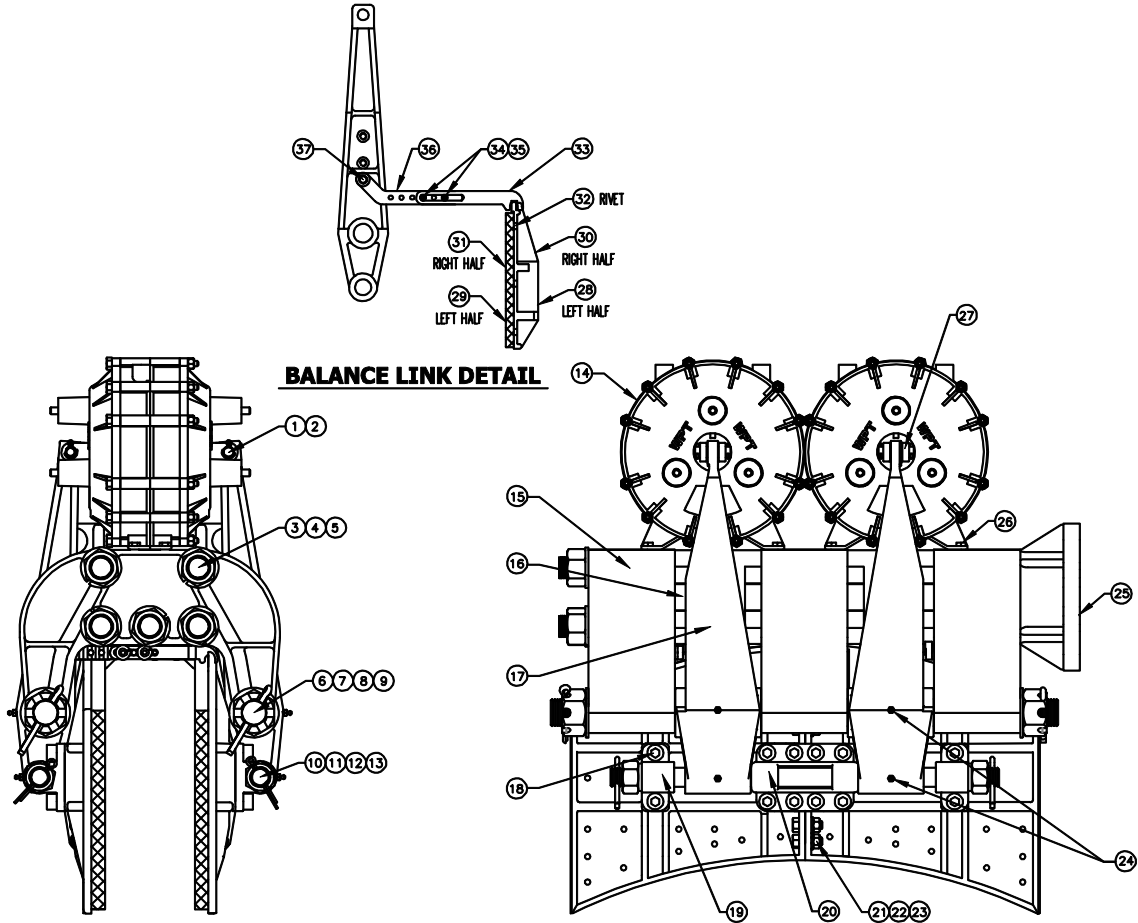

Item	Description	Qty	Item	Description	Qty
1	Lever Pin	4	20	Bearing, Center	2
2	Cotter Pin	8	21	HHCS	10
3	Tie Rod	5	22	Nut	10
4	Nut, Tie Rod	5	23	Lock Washer	10
5	Lock Washer, Tie Rod	5	24	Grease Zerk	8
6	Saddle Rod	2	25	Foot, Mounting	1
7	Nut, Saddle Rod	4	26	HHCS, Actuator Assembly	8
8	Washer, Saddle Rod	4	27	Clevis Pin	4
9	Cotter Pin, Saddle Rod	4	28	Shoe, Left	2
10	Shoe Rod	2	29	Friction Lining, Left	2
11	Nut, Shoe Rod	4	30	Shoe, Right	2
12	Lock Washer, Shoe Rod	4	31	Friction Lining, Right	2
13	Cotter Pin, Shoe Rod	4	32	Rivet	124
14	Actuator Assembly	2	33	Balancing Link, Half	2
15	Saddle	3	34	Washer, Balancing Link	4
16	Spacer	2	35	SHCS, Balancing Link	4
17	Lever	4	36	Balancing Link, Half	2
18	SHCS	24	37	Link Pin, Balancing Link	2
19	Bearing, Outer	4			

NOTE: For actual drawing and parts list, contact WPT. Use assembly no./serial no. to identify your unit.

13.0 GENERAL STORAGE GUIDELINES

Upon receipt of parts or assemblies, they should be inspected for corrosion or other related damage. If any problem is detected, contact WPT's warranty department.

It is the owner's primary responsibility to store and protect the WPT product.

Products should be stored in a manner that it is protected from the environment and outside sources, which may include but are not limited to the following:

- **Environmental storage requirements should be maintained as follows:**
 - **No exposure to rainwater**
 - **Temperatures 32F° (0C°) to 110F° (43C°)**
 - **Below 50% average humidity**
 - **Average sunlight**

- **Hazards that require addition protection:**
 - **Dust and debris**
 - **Oil, water, saltwater, acids, or other chemicals**
 - **Any other foreign items which may damage the product**
 - **Other measures include covering the product to prevent ingress of foreign matter**

- **Additional Protection Measures for Long-Term Storage**
 - (For storage exceeding one month):**
 - **Coat exposed metal with Cosmoline RP-342 "HEAVY" Military-Grade Rust Preventive Aerosol Spray, or equal**
 - **Coating of painted surfaces is not required or recommended**
 - **Visually inspect the product for degradation once every three-months**

WPT Power
1600 Fisher Road - Wichita Falls, TX 76305
P.O. Box 8148 - Wichita Falls, TX 76307
Ph. 940-761-1971
www.WPTpower.com